

A SERIES 132 PARTITIONS

PRODUCT SUMMARY

A Series 132 Aluminium Partition System provides a central line glazing with numerous configurations and design options, offering a complete partition system for plasterboard and glazing.

- Standard profile size of 132mm x 25mm, 132mm x 35mm, 132mm x 50mm
- Standard wall size based on 92mm steel stud with either a single or double layer of 13mm plaster board on each side
- Can accommodate glass thicknesses between 6mm and 13mm
- Door thicknesses between 35mm and 50mm can be used
- Shadowline details optional

FINISHING OPTIONS

- The range is stocked in either a Mill or Anodised finish, or can be Powdercoated to a colour of your choice, including our exclusive 'Potters Black' and various MetWood finishes
- An antimicrobial coating can also be applied for use in hygiene and medical spaces
- We also specialise in custom specifications upon request

DS SERIES DOORS + SLIDERS

- Designed to fit with Potter aluminium partition systems - available in 35mm thick doors only
- Styles and rail sizes 45mm, 75mm, 100mm, 120mm and 150mm
- Can accommodate 13mm thick laminated glass
- Sliding doors available in numerous configurations based around the 38mm door series

SUSTAINABILITY

- All our aluminium partition suites carry the Declare label - ensuring they contain no harmful chemicals
- Final assembly: New Zealand
- Life expectancy: 50+ years.
- End of of life options: 100% reusable/recyclable



Scan For Further Product Information
And Product Technical Statements.
www.potters.co.nz 0800POTTERS



HANDLING, STORING AND MAINTENANCE

Aluminium has a high natural resistance to corrosive conditions. The principal things to guard against are surface abrasions or water stains. Water stain is a superficial condition and the mechanical properties of the metal are not affected.

If aluminium arrives in a wet condition, it should be thoroughly dried before storing. This may be done by evaporation or through dry air currents. When the moisture is removed within a short period, no stain will result. The metal should not be stored near obvious water sources and should be kept at a reasonable distance from open doors and windows.

CLEANING

The surface of fabricated aluminium, whether untreated, anodised or coated, can be spoiled by improper care. Usual care is no more than periodic cleaning. If cleaned reasonably frequently then the mildest methods of washing will produce satisfactory results. The type of cleaning is governed by the finish, degree of soiling, size, shape and location.

The following cleaning methods are listed in order of mild to harsh. The mildest treatment should be tried on a small area and if not satisfactory only then should the next be examined.

1. Plain water
2. Water with mild soap or detergent
3. Solvents, e.g. kerosene, turpentine, white spirit
4. Non-etching chemical cleaner
5. Wax-base polish
6. Abrasives + Abrasive wax











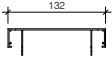
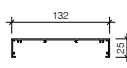

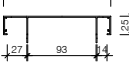

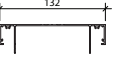

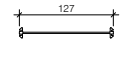
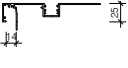
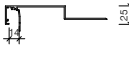
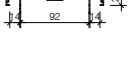
After applying the cleaning agents, the surface should be washed down thoroughly and dried with a clean cloth to prevent streaking. If using proprietary cleaners, the manufacturer's recommendation should be obtained and followed carefully. If abrasives are used, the aluminium finish may be altered.

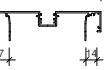
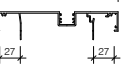
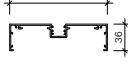
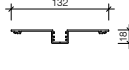
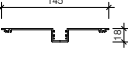
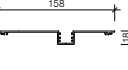
If there is a grain in the finish then cleaning should be performed with the grain. When all other methods fail it may be necessary to resort to heavy-duty cleaning. This involves the use of cleaners containing strong etching chemicals or coarse abrasives.

WARRANTY

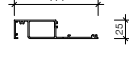
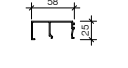
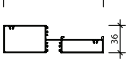
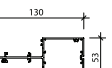
Designed and produced in New Zealand, our proven range of aluminium partitioning suites carry a ten (10) year warranty from the date of installation. (Subject to terms + conditions)

STANDARD PROFILES

 PAS310 92MM CAPPING	 PAS310/A 92MM HEAD/FRAME	 PAS310/C SHADOWLINE HEAD TRACK	 PAS310/SD HEAD TRACK SINGLE DOUBLE	 PAS310/DD HEAD TRACK DOUBLE DOUBLE	 PAS310/R 92MM REBATED HEAD TRACK
 PAS311 SNAP IN FLUSH PANEL	 PAS311/D SNAP IN ADAPTOR	 PAS313/A ADJ MULTI TRACK A	 PAS313/B ADJ MULTI TRACK B	 PAS314 POCKET CAPPING / FRAME	 PAS314/A GLAZING POCKET ADAPTOR
 PAS314/SD GLAZING POCKET SINGLE DOUBLE	 PAS314/DD GLAZING POCKET DOUBLE DOUBLE	 PAS315 MED POCKET CAPPING / FRAME	 PAS316 SNAP IN POCKET	 PAS316/SD SNAP IN POCKET SINGLE DOUBLE	 PAS316/DD SNAP IN POCKET DOUBLE DOUBLE
 PAS317 SNAP IN DOORSTOP 40MM DOOR	 PAS318 SNAP IN DOORSTOP 50MM DOOR	 PAS318-P D/STOP TO 50MM P/COAT 5.6LM	 PAS319 GLAZING SILL/BAR	 PAS320 GLAZING BEAD	 PAS321/A TRANSOM/MULLION/DOOR FRAME
 PAS321/B TRANSOM/MULLION/DOOR FRAME	 PAS322 TRANSOM BEAD	 PAS324 LARGE GLAZING SILL / TRANSOM BEAD	 PAS324/JX 90° CORNER POST	