



## DATASHEET

# E SERIES 132 PARTITIONS

### PRODUCT SUMMARY

The E Series is a contemporary glass partition system. This robust aluminium suite offers an edgeline or twin-glazing design that delivers premium aesthetics in any commercial setting.

- Standard detail of 132mm x 25mm, 132mm x 35mm or 132mm x 50mm
- Edgeline or twin glazing design
- Can accommodate glass thicknesses between 6mm and 13mm
- Door thicknesses of 35mm – 45mm can be used
- Standard wall size based around 92mm steel stud with one layer of 13mm plaster board on each side

### FINISHING OPTIONS

- The range is stocked in either a Mill or Anodised finish, or can be Powdercoated to a colour of your choice, including our exclusive 'Potters Black' and various MetWood finishes
- An antimicrobial coating can also be applied for use in hygiene and medical spaces
- We also specialise in custom specifications upon request

### DS SERIES DOORS + SLIDERS

- Designed to fit with Potter aluminium partition systems - available in 35mm thick doors only
- Styles and rail sizes 45mm, 75mm, 100mm, 120mm and 150mm
- Can accommodate 13mm thick laminated glass
- Sliding doors available in numerous configurations based around the 38mm door series

### SUSTAINABILITY

- All our aluminium partition suites carry the Declare label - ensuring they contain no harmful chemicals
- Final assembly: New Zealand
- Life expectancy: 50+ years.
- End of of life options: 100% reusable/recyclable



## HANDLING, STORING AND MAINTENANCE

Aluminium has a high natural resistance to corrosive conditions. The principal things to guard against are surface abrasions or water stains. Water stain is a superficial condition and the mechanical properties of the metal are not affected. If aluminium arrives in a wet condition, it should be thoroughly dried before storing. This may be done by evaporation or through dry air currents. When the moisture is removed within a short period, no stain will result. The metal should not be stored near obvious water sources and should be kept at a reasonable distance from open doors and windows.

## CLEANING



The surface of fabricated aluminium, whether untreated, anodised or coated, can be spoiled by improper care. If cleaned reasonably frequently then the mildest methods of washing will produce satisfactory results. The type of cleaning is governed by the finish, degree of soiling, size, shape and location. The following cleaning methods are listed in order of mild to harsh. The mildest treatment should be tried on a small area and then should the next be examined.

1. Plain water with mild soap or detergent
2. Solvents, e.g. kerosene, turpentine, white spirit
3. Non-etching chemical cleaner
4. Wax-base polish
5. Abrasives + Abrasive wax

After cleaning, the surface should be washed and dried with a clean cloth to prevent streaking. If using proprietary cleaners, the manufacturer's recommendation should be followed carefully. If abrasives are used, the aluminium finish may be altered. If there is a grain in the finish then cleaning should be performed with the grain. When all other methods fail it may be necessary to resort to heavy-duty cleaning with strong etching chemicals or coarse abrasives.

## WARRANTY

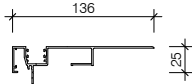
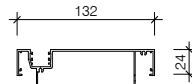
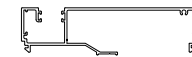
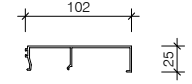
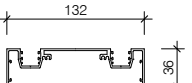
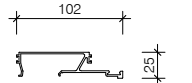
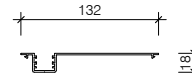
Designed and produced in New Zealand, our proven range of aluminium partitioning suites carry a ten (10) year warranty from the date of installation. (Subject to terms + conditions)

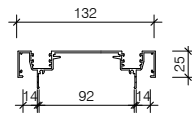
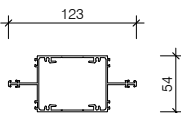
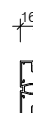
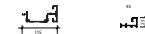
|  |   |   |   |
|--|---|---|---|
|  <p><b>PAS313-E</b><br/>132 ADJ MULTI TRACK A</p> |  <p><b>PAS332</b><br/>132 EDGE POCKET CAPPING</p>    |  <p><b>PAS332/D</b><br/>132 DEEP POCKET CAPPING</p>   |  <p><b>PAS334</b><br/>132 EDGE GLAZING BEAD</p>      |
|  <p><b>PAS335</b><br/>TWIN GLAZE 36MM MULLION</p> |  <p><b>PAS336</b><br/>TWIN GLAZE FRAME BEAD</p>      |  <p><b>PAS338</b><br/>132 EDGE SNAP IN POCKET</p>     |  <p><b>PAS339</b><br/>TWIN GLAZE SNAP IN POCKET</p>  |
|  <p><b>PAS340</b><br/>TWIN GLAZE FRAME</p>        |  <p><b>PAS341</b><br/>TWIN GLAZE TWO PCE TRANSOM</p> |  <p><b>PAS342</b><br/>TWIN GLAZE TWO PCE TRANS CAP</p> |  <p><b>PAS343</b><br/>TWIN GLAZE TWO PCE MULLION</p> |