

SMOKE CONTROL DOOR

INSTALLATION GUIDE

VERSION 1 2023

Introducing the Potter Interior Systems **DS Series Smoke Control Door**, a cutting-edge solution that offers protection from the spread of smoke.

Proudly designed by Potter Interior Systems and manufactured in New Zealand our door system has undergone extensive testing at ambient temperatures in accordance with **AS/NZS 1530.7:1998**.

This comprehensive standard that lays out the protocols for evaluating the smoke leakage in building materials, components, and structures.

The DS Series Smoke Control Door not only complies with the stringent requirements of the New Zealand Building Code (NZBC) and has achieved an outstanding air permeability rate. This rating underscores our commitment to providing top-tier smoke control solutions that enhance safety and performance. Scan QR below for the latest product information.



DS Series

Hinged aluminium door with glass insert

Frame Components	PAS314 (90mm framing)
	PAS317 (90mm framing)
	Schlegel mohair door seal
Door Leaf Components	PAS500/100 stile
	PAS503/100 rail
	PAS504 glazing Bead
	V fin glazing wedge
	Laminated Glass with 8mm yellow wedge
	Firesiticone EMA
	Bostik Expanda foam
	Hinges x 4 and screws
	Allegion Briton - Door Closer 1130
	Allegion Door passage handle set with latch
	action RP8si - drop down seal

DISCLAIMER

The products referred to in this document have been manufactured by or on behalf of Potter interior Systems ('Potters') or CSR Building Products Limited ('CSR') to comply with any relevant standards. While any design or usage guidelines are set out in this document have been prepared in good faith by Potters and CSR, they are of general nature only and are intended to be used in conjunction with project specific design and engineering advice. It is the responsibility of the customer to ensure that Potter's products are suitable for their chosen application, including in respect of project – specific matters such as, but not limited to structural adequacy, acoustic, fire resistance/combustibility, smoke resistance, thermal and weatherproofing requirements. All information relating to design, installation/ application of these products is offered without warranty and no responsibility can be accepted by Potters or CSR for errors and omissions, or for any use of the relevant products not in accordance with Potter's technical literature. For current technical and warranty documentation in relation to Potter's products, visit www.Potters.co.nz or contact your local Potters representative for more information.

SMOKE CONTROL DOOR

INSTALLATION INSTRUCTIONS

1. DOOR FRAME
2. RAIL + STILE
3. RAVEN SEAL RP8Si
4. FOAM
5. DOOR HANDLE
6. DOOR HINGE
7. DOOR CLOSER
8. RAVEN SEAL RP120
9. GLASS & GLAZING BEAD

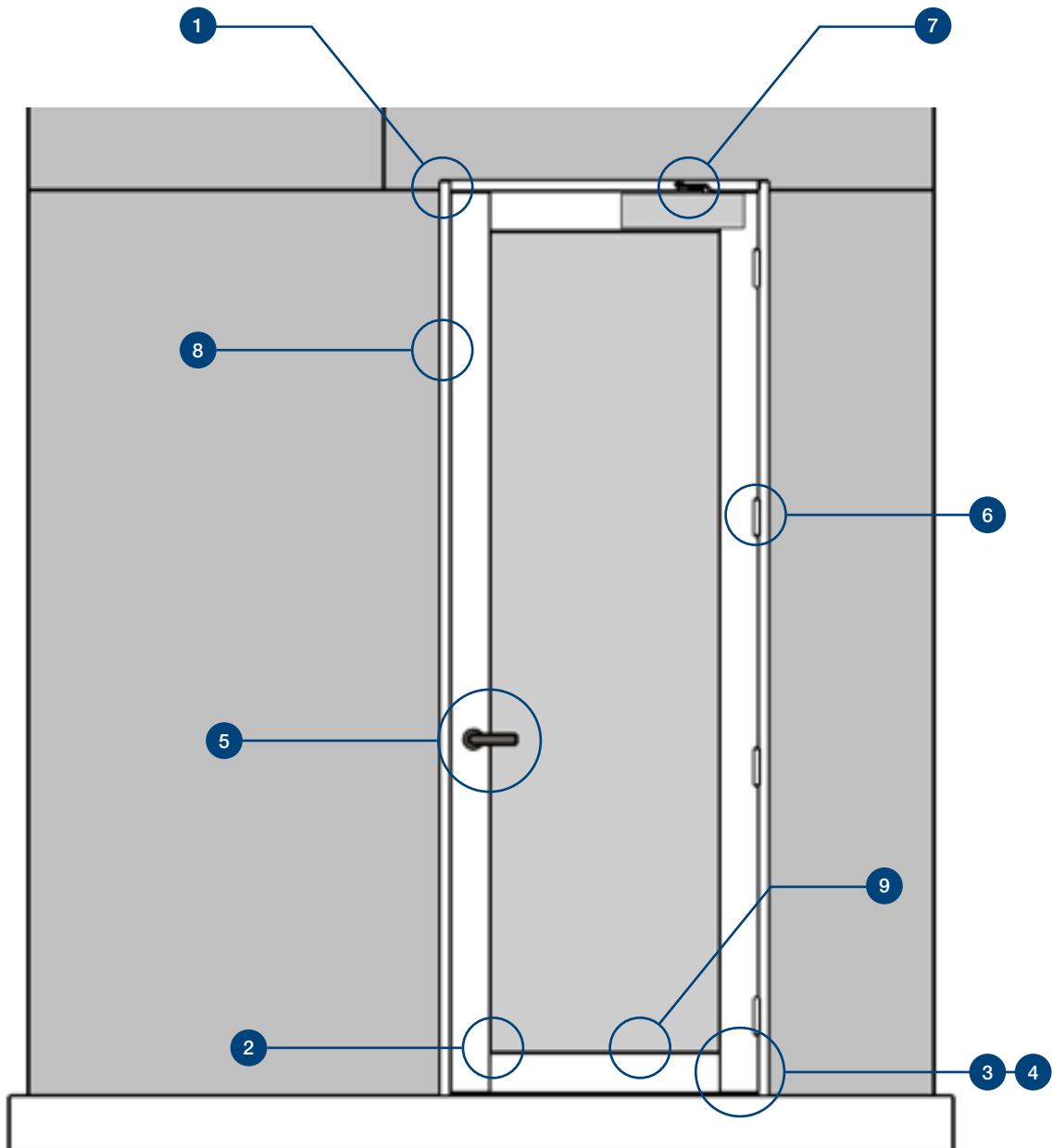

1. ALUMINIUM DOOR FRAME

Fix the Frame using Potter Interior Systems
6GX30 DRILL POINT GYPSUM SCREW (459209)

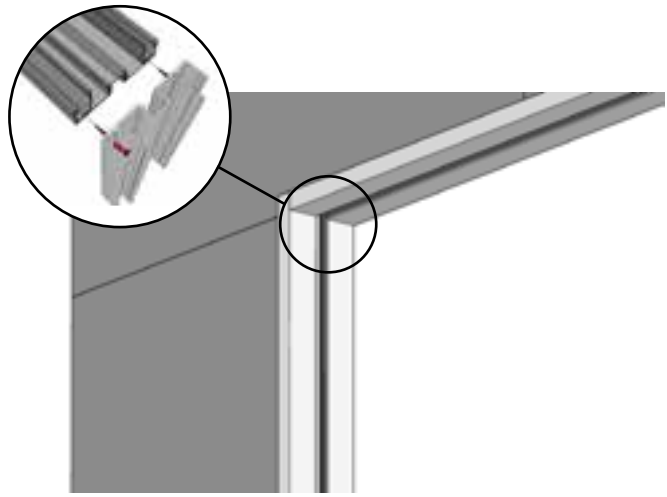

2. DOOR STOP AND SEAL

After clipping PAS017 into PAS014 (as shown)
Or PAS317 into PAS314 apply the Raven Seal
RP120 on the door stop and frame along both
the top and sides.

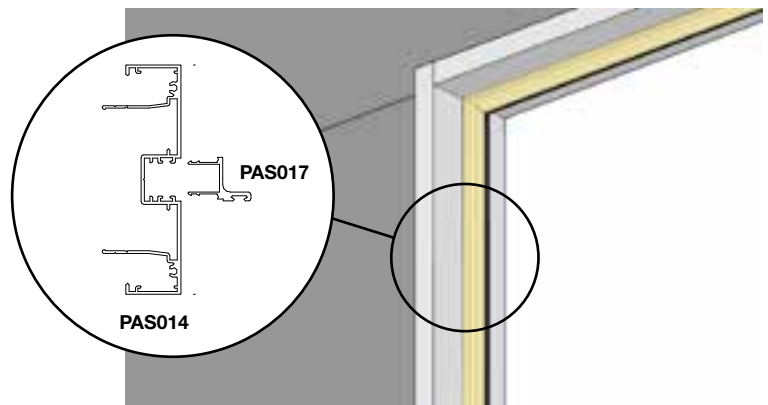

3. RAVEN SEAL RP120 FRAME

Raven seal RP120 to be applied along the door stop as
per the manufacturers installation guide, which can be
downloaded with the QR code.

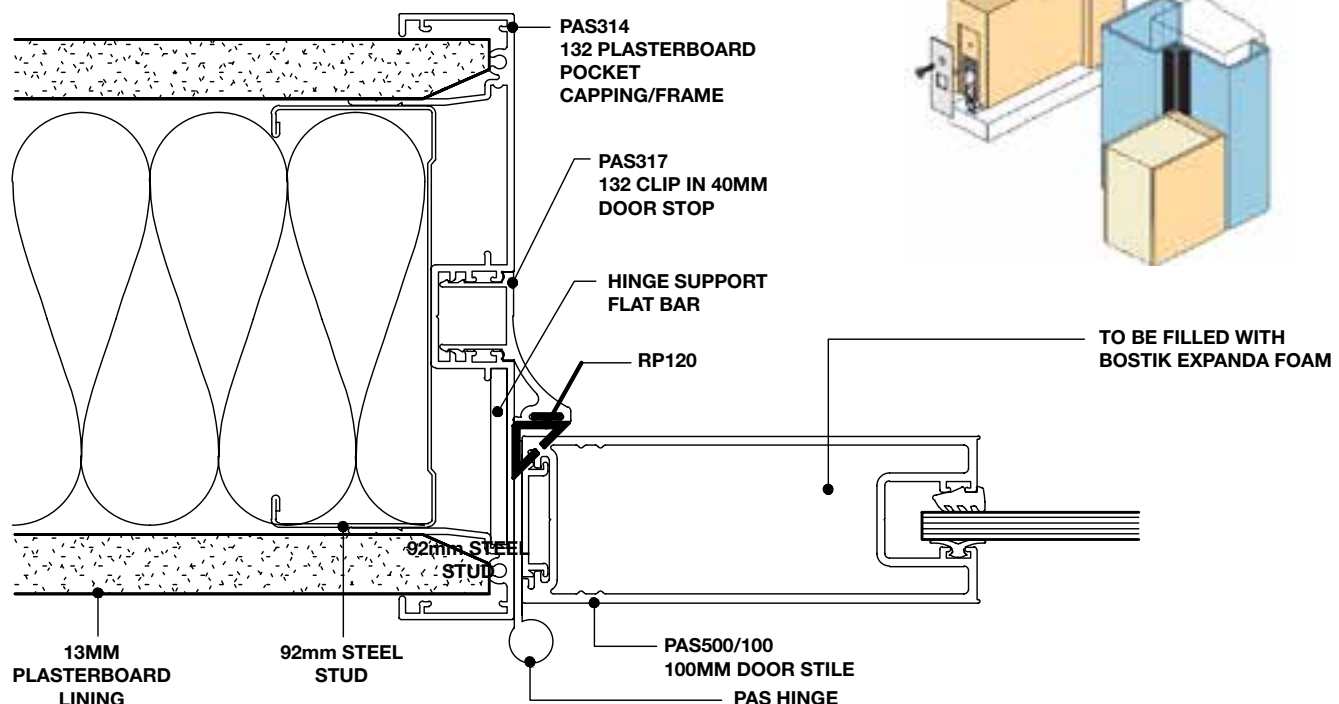
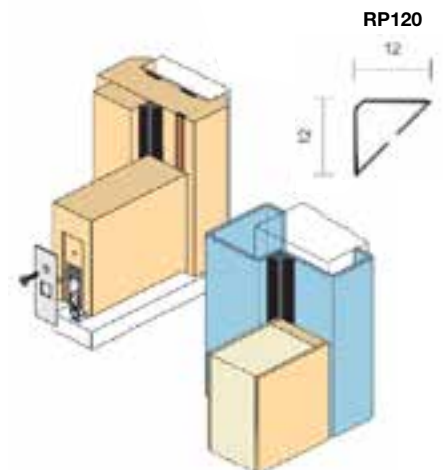
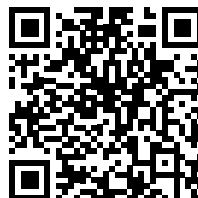

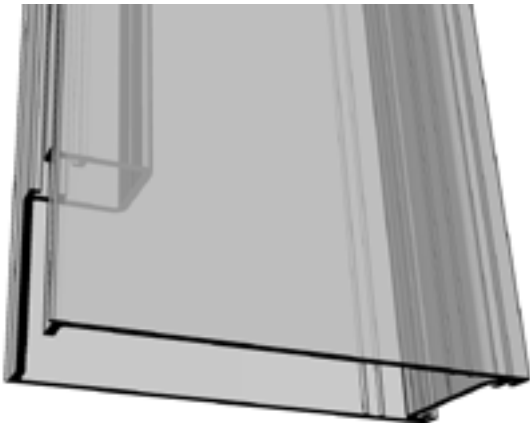

4. RAVEN SEAL RP8Si

Make a cut out in the bottom of the Stiles as shown. The cut out size is governed by Raven Seal RP8Si, as per the manufacturers installation guide, which can be downloaded with the QR code below.

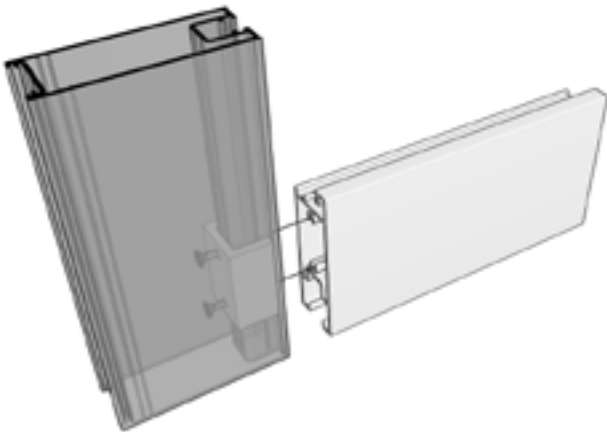
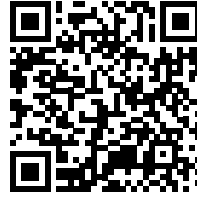

5. RAIL + STILE

Fix the Rail to the Stile using the UC Braces and Potter Interior Systems Screws
M5X60 CSK SQ T23 Hardened MTS ZP (461397)

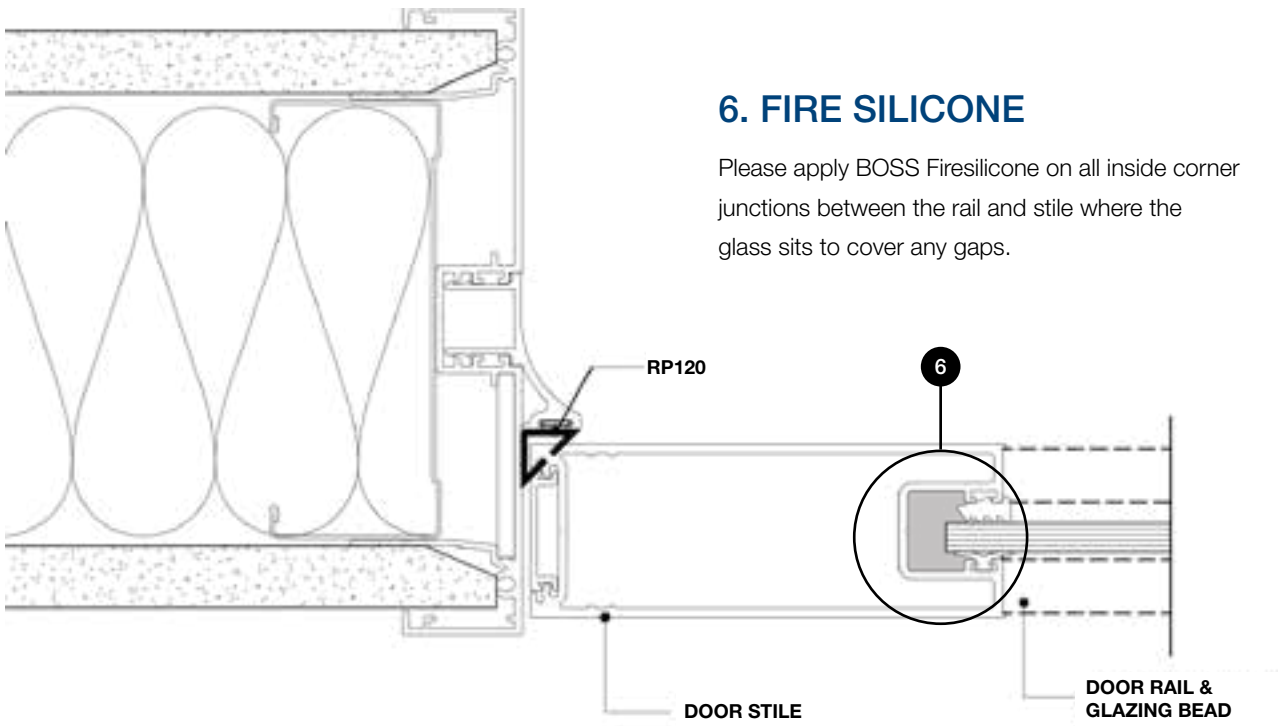

6. FIRE SILICONE

Please apply BOSS Firesilicone on all inside corner junctions between the rail and stile where the glass sits to cover any gaps.

7. FOAM + RP8Si

Insert Bostik Expanda Spray Foam into the top and bottom of the door frame Stiles. Once the foam is set, cut out the excess foam to match the door profile.

Please install Raven Seal RP8Si as per the manufacturers installation guide, which can be downloaded with the QR code below.

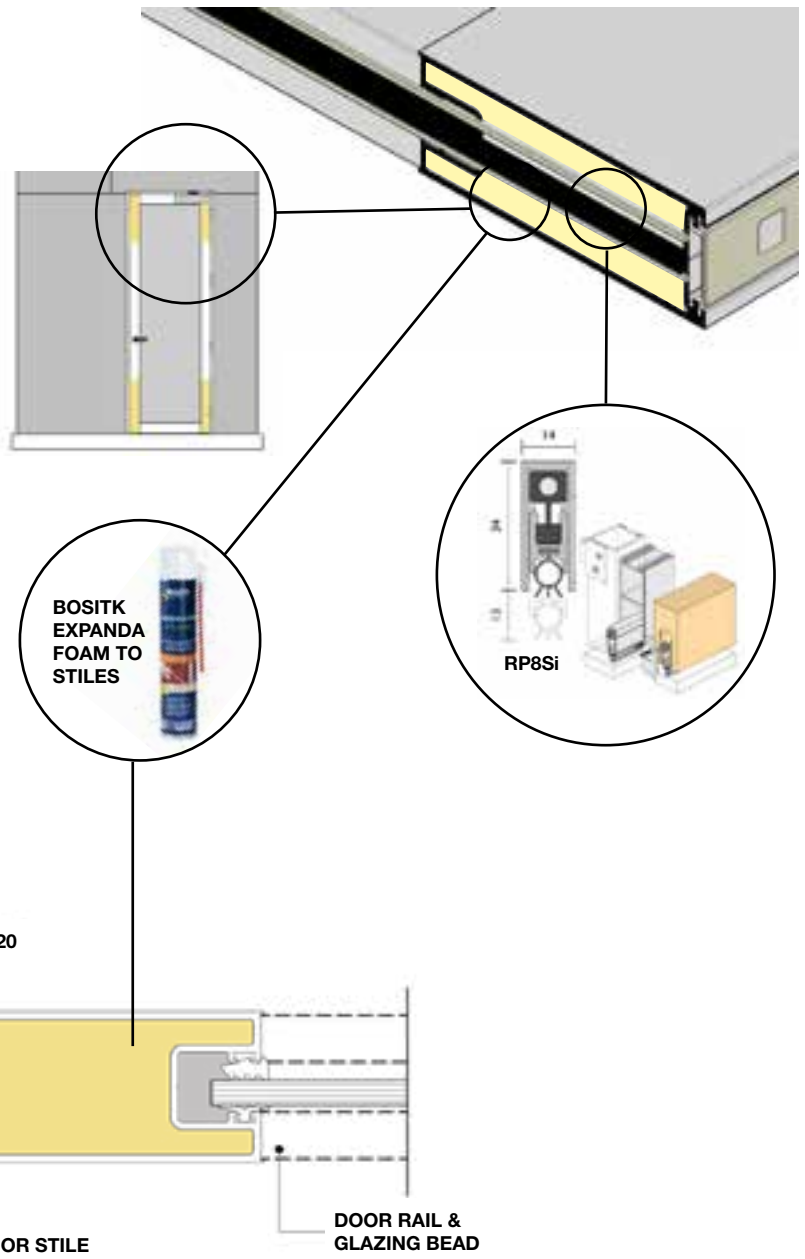

8. DOOR HINGE

Door hinges to be installed using Potter Interior Systems Hinge Screws.

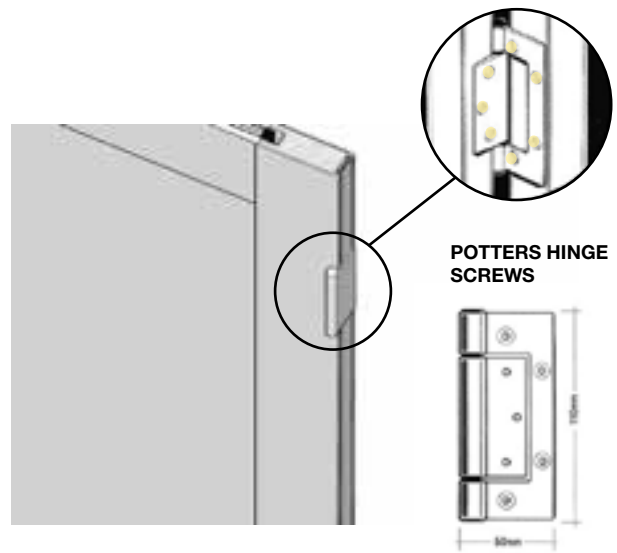

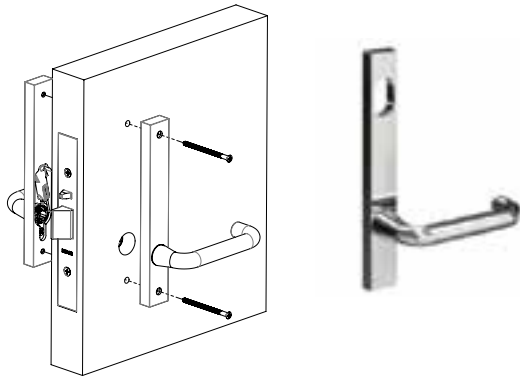

9. DOOR HANDLE

Please install your Allegion Door Handle as per the manufacturers installation guide which can be downloaded at the QR code below.



Fire Silicone must also be applied around the handles to seal any gaps.

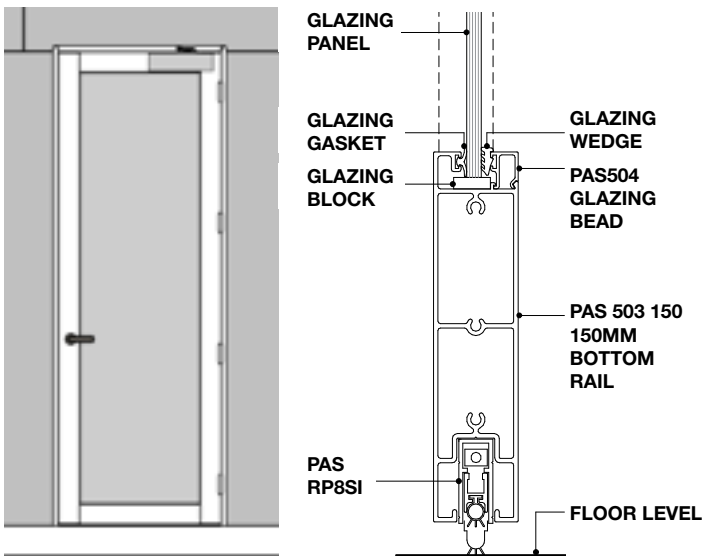

10. GLASS & GLAZING BEAD INSTALLED

Use a glazing gasket on the Door Rail, Stile and Glazing Beads. The glazing panel is to be fixed as per shuffle glazing requirements and clipped into place using the glazing bead.

11. ALLEGION DOOR CLOSER

Install Allegion Door Closer BN1130 as per the manufacturers installation guide which can be downloaded at the QR code below.



After installation please ensure the self closer is working correctly by checking it at least 10 times as required by the code to ensure the latch action works each time when closing at 30 Degree angle.

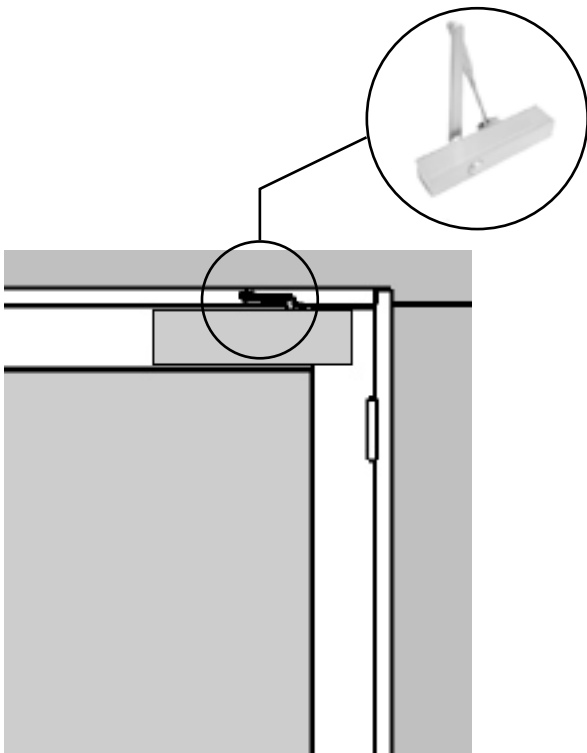



0800 POTTERS
www.potters.co.nz

AUCKLAND + HEAD OFFICE

393 Church Street, Penrose
PO Box 13 451, Onehunga 1643
Phone 09 579 1338

HAMILTON

127A Maui Street, Pukete
PO Box 10 372, Te Rapa, Hamilton 3241
Phone 07 846 0050

WELLINGTON

20 Hutt Road, Petone
PO Box 33 338, Petone, Lower Hutt 5046
Phone 04 568 8855

CHRISTCHURCH

90 Antigua Street, Addington
Phone 03 338 8763

Declare.  SM

Wall | Ceiling | Insulation | Passive Fire | Whiteboards + Pinboards
